

NICE AND EASY - VIACON STEEL PRODUCTS

HelCor®
Underground retention tanks
MultiPlate MP200
SuperCor®
UltraCor®
Acrow

NICE AND EASY - VIACON STEEL PRODUCTS

TABLE OF CONTENTS

HelCor®	6
Underground retention tanks	18
MultiPlate MP200	24
SuperCor®	38
UltraCor®	56
Acrow	66

DIVERSE MARKETS

ROADS



RAILWAYS



FORESTS



WATERWAYS



MININGS



MILITARY



OTHERS



HelCor[®]



SPIRAL OF OPPORTUNITIES





Helically corrugated steel pipes HelCor® and pipe-arches HelCor PA produced by ViaCon can make up complete systems used in civil engineering as:



- roads and railway culverts
- underground passages
- ecological passages
- hydrotechnical structures
- relining of deteriorated structures

Introduction

The history of corrugated steel pipes dates back to 1896, when its production was started in the United States. The first helically corrugated steel pipes were also produced at that time in Russia, where 1300 m of this product was used as culverts under the railway lines. In Poland, the pipes appeared at the end of the 1970s and since then they have been increasingly popular among designers and contractors.



Complete system of helically corrugated pipes includes elbows, T-connections and additional elements such as manholes, inspection chambers etc.

Installation time of HelCor® and HelCor PA is much shorter than for concrete pipes. Easy and quick assembly helps to limit the construction time of culverts or other structures and allows construction of the pipe culvert in stages without stopping the traffic. Construction of culverts with the use of HelCor® and HelCor PA is much more economical than traditional concrete culverts. Construction can also take place during the winter time or cold weather conditions.

Steel

Tab. 1. HelCor® and HelCor PA steel pipes mechanical properties

HelCor® and HelCor PA steel pipes mechanical properties				
Steel grade	Standard	Yield point R _e [MPa]	Tensile strength R _m [MPa]	Elongation A _{50min} [%]
DX51D	PN-EN 10346	-	270 - 500	22
S250GD		250	330	19

Steel used for the production of HelCor® and HelCor PA pipes, as well as coupling bands, conform to the European Standards:

PN-EN 10346:2011 „Continuously hot-dip coated steel flat products – Technical delivery conditions”

Steel is delivered in coils, with a protection coating in accordance to a/m standards:

- 600 g/m zinc coating total both sides, equivalent to 42 µm on each side
- 1000 g/m zinc coating total both sides, equivalent to 70 µm on each side
- 600 g/m zinc coating both sides, equivalent to 42 µm on each side, with an additional 300 µm polymer film (Trenchcoat™ or W-Protect™) on one or both sides

HelCor® and HelCor PA pipes are produced from steel coils with thickness ranging from 1,5 mm to 3,5 mm in two types of corrugations:

- D1 - 68 x 13 mm
- D3 - 125 x 26 mm

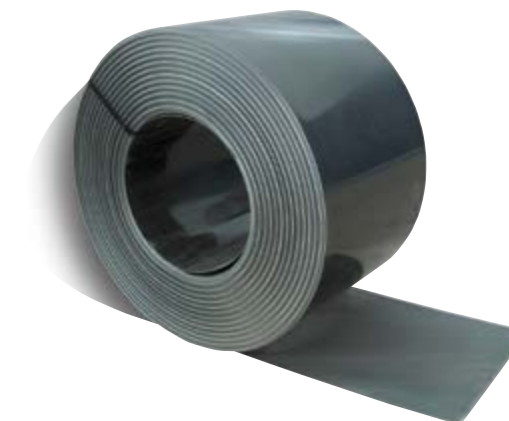



Section lengths and coupling bands

The standard lengths of HelCor® pipes are 6 m, 7 m and 8 m, however the production process allows the manufacture of pipes in any length. The pipearches are produced up to 10 m long (6 m standard length).

Pipes can be bevel cut in the factory in accordance with the design to conform the slope and the skew angle of the embankment.

Cut ends of the pipe are protected against corrosion by painting the cut sections. In order to obtain the designed length of the pipe, several lengths can be joined together with coupling bands.



The coupling bands are made of flat or corrugated steel sheets. Depending on the diameter and purpose of the pipe, different types and widths of coupling bands are used:

- TYPE 1:**
flat connected by bolts
- TYPE 2:**
helically corrugated connected by bolts
- TYPE 3:**
helically corrugated connected by bolts in tubes (for relining)
- TYPE 4:**
annularly corrugated for connection of pipes with re-corrugated ends
- TYPE 5:**
flat with annular corrugation for connection of pipes with recorrugated ends

Geometric properties of coupling bands are adjusted to the geometry of HelCor® pipes.





Tab.2. Technical specification for HelCor® pipes

Type	Span/rise [m]	Cross section [m ²]	Substitute diameter** [mm]	Corrugation	Zinc protection		Zinc coating + Trenchcoat layer	
					Plate thickness* [mm]	Weight [kg/m]	Plate thickness* [mm]	Weight [kg/m]
HCPA-S1	0,80/0,58	0,38	700	D1	1,5 / 2,0	40,5	1,6 / 2,0	41,7
HCPA-S2	0,91/0,66	0,50	800	D1	1,5 / 2,0	46,2	1,6 / 2,0	47,7
HCPA-S3	1,03/0,74	0,63	900	D1	1,5 / 2,0	52,0	1,6 / 2,0	53,6
HCPA-S4	1,15/0,82	0,79	1 000	D1	2,0 / 2,5	57,8	2,0 / 2,5	59,6
HCPA-01	1,34/1,05	1,13	1 200	D1	2,0 / 2,5	86,7	2,0 / 2,5 / 2,7	88,8
HCPA-02	1,44/0,97	1,10	1 210	D1	2,0 / 2,5	87,4	2,0 / 2,5 / 2,7	89,6
HCPA-03	1,49/1,24	1,46	1 360	D1	2,0 / 2,5	98,3	2,0 / 2,5 / 2,7	100,7
HCPA-04	1,62/1,10	1,42	1 350	D1	2,0 / 2,5	97,5	2,0 / 2,5 / 2,7	99,9
HCPA-05	1,65/1,38	1,82	1 510	D1	2,0 / 2,5	109,1	2,0 / 2,5 / 2,7	111,8
HCPA-06	1,80/1,20	1,70	1 510	D1	2,5 / 3,0	130,9	2,5 / 2,7 / 3,0	133,6
HCPA-07	1,80/1,50	2,15	1 650	D1	2,5 / 3,0	143,0	2,5 / 2,7 / 3,0	146,0
HCPA-08	1,84/1,39	2,04	1 620	D1	2,5 / 3,0	140,4	2,5 / 2,7 / 3,0	143,3
HCPA-09	1,84/1,48	2,16	1 660	D1	2,5 / 3,0	143,9	2,5 / 2,7 / 3,0	146,9
HCPA-10	1,89/1,55	2,32	1 720	D1	2,5 / 3,0	149,1	2,5 / 2,7 / 3,0	152,2
HCPA-11	1,91/1,46	2,23	1 700	D1	2,5 / 3,0	147,4	2,5 / 2,7 / 3,0	150,4
HCPA-12	1,95/1,32	2,04	1 640	D1	2,5 / 3,0	142,2	2,5 / 2,7 / 3,0	145,1
HCPA-13	2,01/1,59	2,55	1 810	D1	2,5 / 3,0	156,9	2,5 / 2,7 / 3,0	160,1
HCPA-14	2,04/1,49	2,41	1 770	D1	2,5 / 3,0	153,5	2,5 / 2,7 / 3,0	156,6
HCPA-15	2,10/1,45	2,42	1 810	D1	2,5 / 3,0	156,9	2,5 / 2,7 / 3,0	160,1
HCPA-16	2,10/1,55	2,59	1 830	D1	3,0	158,7	2,7 / 3,0	161,9
HCPA-17	2,14/1,64	2,74	1 920	D1	3,0	166,5	2,7 / 3,0	169,9
HCPA-18	2,16/1,62	2,80	1 920	D1	3,0	166,5	2,7 / 3,0	169,9
HCPA-19	2,20/1,71	2,99	1 960	D1	3,0	169,9	2,7 / 3,0	173,4
HCPA-20	2,23/1,68	2,93	1 960	D1	3,0	169,9	2,7 / 3,0	173,4
HCPA-21	2,28/1,70	3,03	2 010	D3	3,5	214,1	3,5	217,8
HCPA-22	2,35/1,77	3,28	2 060	D3	3,5	219,4	3,5	223,3
HCPA-23	2,35/1,73	3,16	2 040	D3	3,5	217,3	3,5	221,1
HCPA-24	2,37/1,83	3,45	2 060	D3	3,5	219,4	3,5	223,3
HCPA-25	2,48/1,79	3,47	2 140	D3	3,5	227,9	3,5	231,9
HCPA-26	2,49/1,83	3,61	2 160	D3	3,5	230,1	3,5	234,1
HCPA-27	2,55/1,86	3,73	2 200	D3	3,5	234,3	3,5	238,4
HCPA-28	2,58/1,94	3,97	2 260	D3	3,5	240,7	3,5	244,9
HCPA-29	2,60/1,93	3,97	2 260	D3	3,5	240,7	3,5	244,9
HCPA-30	2,75/1,95	4,20	2 355	D3	3,5	250,8	3,5	255,2
HCPA-31	2,76/2,05	4,48	2 400	D3	3,5	255,6	3,5	260,1
HCPA-32	2,80/2,01	4,43	2 400	D3	3,5	255,6	3,5	260,1
HCPA-33	2,84/2,02	4,58	2 430	D3	3,5	258,8	3,5	263,4
HCPA-34	2,95/2,04	4,69	2 510	D3	3,5	267,3	3,5	272,0
HCPA-35	2,96/2,16	5,06	2 550	D3	3,5	271,6	3,5	276,4
HCPA-36	2,97/2,00	4,57	2 490	D3	3,5	265,2	3,5	269,9
HCPA-37	3,08/2,08	4,94	2 580	D3	3,5	274,8	3,5	279,6
HCPA-38	3,14/2,27	5,63	2 710	D3	3,5	288,6	3,5	293,7
HCPA-39	3,17/2,06	5,12	2 620	D3	3,5	279,1	3,5	284,0
HCPA-40	3,23/2,12	5,41	2 680	D3	3,5	285,4	3,5	290,5
HCPA-41	3,23/2,15	5,39	2 710	D3	3,5	288,6	3,5	293,7
HCPA-42	3,28/2,17	5,67	2 720	D3	3,5	289,7	3,5	294,8
HCPA-43	3,33/2,23	5,97	2 800	D3	3,5	298,2	3,5	303,5
HCPA-44	3,33/2,39	6,29	2 870	D3	3,5	305,7	3,5	311,1
HCPA-45	3,35/2,19	5,65	2 790	D3	3,5	297,2	3,5	302,4
HCPA-46	3,38/2,25	5,60	2 825	D3	3,5	300,9	3,5	306,2
HCPA-47	3,49/2,27	6,28	2 880	D3	3,5	306,8	3,5	312,1
HCPA-48	3,52/2,49	6,91	3 000	D3	3,5	319,5	3,5	325,1
HCPA-49	3,65/2,39	6,85	3 040	D3	3,5	323,8	3,5	329,5
HCPA-50	3,67/2,61	7,52	3 160	D3	3,5	336,6	3,5	342,5

* Plate thickness tolerances acc. to EN 10143:1997

** Diameter of pipe before forming into pipe arch

In case of necessity of customized shape or plate thickness, please contact Technical Department.



For the same water level the pipe-arch shape has 65%-100% more water flow capacity than a round pipe with the same rise.

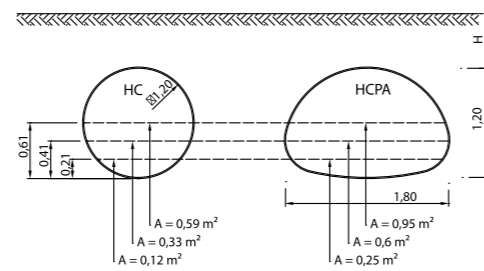

Fig. 1. Comparing water flow capacity of HelCor® and HelCor PA pipes





Additional corrosion protection by painting

Coating steel with a polymer film, called Trenchcoat™, is a technique invented, patented and used in USA since 1974 and in Europe since the beginning of 1998.

The zinc coated steel strip is covered with a polymer film in a fully controlled in-house process. As a result, a very smooth and highly adhesive layer of polymer film protects the galvanized coating. The production process conforms to PN-EN 10169-1+A1:2012 (W-Protect™) and ASTM 742 (Trenchcoat™).



Trenchcoat™ film can be applied on either one or both sides of the pipe.

Protection obtained in such process is the best way to protect against natural corrosion in zinc and steel, and it can also protect against mechanical damage due to abrasion and chemical corrosion. Research findings indicate that the Trenchcoat™ film is very effective in resisting aggressive chemicals.

Trenchcoat™ is the best corrosion protection available on the culvert market today. It can provide over 100 years life-time in most environmental conditions.

The dielectric strength of Trenchcoat™ is 86,6 kV/mm which gives 25,9 kV for the thickness of 300 µm. This greatly outweighs the voltage of the stray currents arising within the electrified railway lines subgrade.

Using Trenchcoat™ provides absolute protection against the corrosion potentially caused by stray currents.

In special cases additional corrosion protection can be applied to the galvanized pipe with additional paint with thickness up to 400 µm. Please contact the ViaCon Technical Department for further information.



Pipe end finishing

Using HelCor® and HelCor PA pipes enables accurate adjustment of both ends to fit the slope and required angle. A bevel cut can be done on one or both sides with full bevel or step bevel. It is recommended to use a vertical step of 1/3 of the height of the pipe.

The embankment slopes in the inlets and outlets areas may be reinforced in several ways:

Vertical end pipe:

- vertical reinforced concrete head wall
- vertical wall made of gabions

Bevel end pipe:

- reinforcement of the slope with concrete or stone blocks placed on sand-cement mix
- reinforcement with perforated concrete panels
- reinforcement with stone riprap
- stiffening with reinforced cast-in-place concrete collar

Culverts with an intersection angle other than 90 degrees may be manufactured with square or beveled ends. The minimum allowable skew angle is 55°.

In special cases additional reinforcement of the skewed area of the pipe may be necessary.

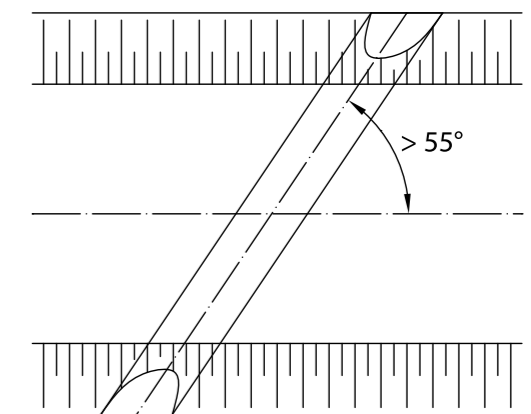

Fig. 2. Skewed structure





Cover depth

Definition of the cover depth for road structures

Cover depth can be described as a vertical distance between the top of the culvert and the road gradeline, including the road pavement.

Tab. 3. Cover depth

Type of structure	Minimum cover depth
Cover depth for road structures	$H_{min} = \max \begin{cases} (B/8)+0,2 \text{ [m]} \\ B/6 \text{ [m]} \\ 0,6 \text{ [m]} \end{cases}$
Cover depth for railway structures	$H_{min} = \max \begin{cases} B/4 \\ 0,6 \text{ [m]} \end{cases}$

B – diameter or pipe span [m]

Definition of the cover depth for railway structures

Cover depth for culvert under railway can be described as a vertical distance between the top of the culvert and the bottom of the railway sleeper, including the construction layers of the railroad.

In case of construction traffic occurring over the pipe, the cover depth must be checked by the ViaCon's Technical Department.

Material for bedding and backfill

- gravel, sand-gravel mix, all-in aggregates and crushed stone can be used as bedding and backfill material
- aggregate grain size depends on the size of corrugation profile
- aggregate size should not exceed 31,5 mm, at the extend of (0,3 m ÷ 0,5 m) outside the pipe wall
- the use of cohesive soil, organic soil and soils including frozen material is not acceptable
- backfill material around the structure should be built in layers of thickness 30 cm and then compacted symmetrically on both sides of the culvert
- uniformity coefficient $C_u \geq 4$
- curvature coefficient $1 \leq C_c \leq 3$
- permeability $k_{10} > 6 \text{ m/day}$
- backfill material should be compacted to minimum 0,98 Standard Proctor Density, (0,95 of Standard Proctor Density is acceptable in the zone directly adjacent to the pipe)

Deviation from these principles requires consultation with ViaCon Technical Department.



New helically corrugated steel pipes HelCor® Bi Pipes



Flexible, cold formed helically corrugated steel pipes, produced as bifid pipes (half pipes), bolted together with L-shape steel elements and longitudinally connected with couplings, can be used in as a steel-soil structures under road and railways loads.

Parameters

- produced diameters – Ø400 mm - Ø1200 mm
- recommended lengths – 6 m
- two types of corrugations – D168x13 mm and 125x26 mm

Three types of corrosion protection

- 42 µm zinc layer (600g/m²)
- 70 µm zinc layer (1000g/m²)
- 42 µm zinc layer (600g/m²) + 300 µm polymer layer Trenchcoating™(TC) or W-Protect™



Underground retention tanks



MODERN SYSTEM OF WATER STORAGE

Underground retention tanks



Tanks made from HelCor® helically corrugated steel pipes manufactured by ViaCon can be used as:

- detention tanks in a gravity storm water drainage systems
- fire fighting water tanks
- process water tanks (pH in the range from 3 to 12)
- settlement tanks for waste water pre-treatment (removal of suspended matter)
- coalescence separators for removal of petroleum derivatives from storm water

Application

As a part of the system ViaCon produces the following ancillary elements of the system:

- pumping stations
- wells
- interceptors and pipelines

High strength parameters of HelCor® pipes allow building the system under roads or car parks - the minimum earth cover over the tank in areas with vehicle traffic allowed is 0.6 m, including structural layers of the pavement.

The maximum installation depth of tanks is ca. 12 m.

Drainage systems consisting of HelCor® pipes have been approved for use in areas affected by mining damages (category I-IV) by Polish Central Mining Institute.



Underground retention tanks



The tanks are manufactured with internal diameters ranging from 1000 to 3600 mm, while the maximum length of a single element is 16 m. This makes it possible to manufacture a tank with a volume of over 150 m³ in one piece, without any assembly of the elements at the construction site. In other arrangements, individual elements are joined together with the use of flange connections that ensure complete leak tightness of the system.

All tank elements are protected against corrosion in the factory by means of a through hot dip galvanizing coating with a thickness of 42 µm, and an additional Trenchcoat™ polymer coating with a minimum thickness of 300 µm. The protection ensures resistance to corrosive action of waste water in the pH range from 3 to 12.



Underground retention tanks



Production of the tanks includes manufacturing of the tank body, bottoms, inspection shafts with ladders, inlet and outlet stub pipes and the connections between tanks. The tanks are manufactured in section of lengths up to 16 m and joined at the construction site with use of flange connections and gaskets.

Tank ends are made of flat metal plates reinforced with ribs depending on the depth of tank foundation and the surcharge loads (earth pressure on the bottom). Both steel flanges and ends are made and welded to the pipe in the factory. After passing the leak tightness test, they are protected against corrosion by painting with zinc rich paint and an addition sealing agent. The anti-corrosion protection of welded joints provides the same durability as that of HelCor® pipes. The connection system provides 100-percent leak tightness of the tank.

Tanks should be installed on an aggregate foundation with a minimum thickness of 30 cm, on a 10 cm thick sand bed - in order to sink the pipe corrugation. In case of high level of groundwater, the state of equilibrium should be checked, considering the uplift of the tank caused by hydrostatic pressure of groundwater. If necessary, additional anchoring or loading of the tank should be provided.

Underground retention tanks



The backfill of the tank should be placed symmetrically on both its sides in layers of thickness not higher than 30 cm. Then compacted to a degree of compaction $I_s \geq 0.98$ according to the standard Proctor test ($I_s \geq 0.95$ is allowed in close proximity of the tank).

Because of the light weight and long lengths of the pipe sections, and the fact that no reinforced concrete founda-

tions are required, the proposed technology of building underground retention tanks from HelCor® pipes can significantly shorten the construction time. This is particularly important in the case of high level of groundwater tables. Thanks to high strength parameters and the proposed anti-corrosion protection, tanks made from HelCor® pipes can be built in principle in all groundwater conditions.

MultiPlate MP200



MULTIPURPOSE TECHNOLOGY

MultiPlate MP200



MultiPlate MP200 structures are used for road, railways and industrial applications such as:

- culverts
- bridges
- overpasses
- tunnels
- underpasses
- ecological crossings
- hangars
- shelters
- warehouses
- conveyor belt protection
- protection of pipes and heat-pipes
- sewage and liquid tanks
- storage bins

Introduction

Galvanized steel components have been successfully used in civil engineering structures for over 100 years. The first applications such of constructions took place in North America and Russia, where the idea of using them in road and rail construction was born. Today, buried corrugated steel structures are widely used in construction around the world. MultiPlate structures are often referred to as flexible structures.

Soil steel interaction allows flexible steel structures to act in conjunction with the surrounding soil fill to support the loads. The structures are economical, easy and quick to build. The average installation time with a small crew is only a few days.

MultiPlate MP200 structures have been used in Europe since 1986. These systems have been manufactured by ViaCon Sp. z o.o. since 2005.



MultiPlate MP200



Approvals and Certificates:

- MultiPlate MP200 has a CE Certificate of Factory Production Control No. 1023-CPR-0640F.
- Technical opinion of the Central Mining Institute (GIG):



**VIACON SYSTEM
FOR CORRUGATED STEEL
BURIED STRUCTURES**

Standard sequence of construction of MultiPlate MP200 structure consists of:

- construction of foundations
- delivery
- assembly
- backfilling
- finishing work

MultiPlate MP200 structures have many advantages, such as:

- simple design due to standard drawings and a calculations database for standard applications
- fast and easy assembly
- assembly possible in temperatures below zero
- assembly possible with no traffic interruptions
- assembly possible with total or partial prefabrication of the structures
- light weight, the corrugated steel plates can be delivered easily and economically to remote locations
- reduction in the total time and cost of construction

Production

MultiPlate MP200 production process involves the mechanical shaping of flat steel plates into corrugated curved plates which are later hot-dip galvanized. The finished corrugated plates can also be epoxy painted on request. All of the manufacturing takes place in a quality controlled factory process.

Steel used for production of MultiPlate MP200 conforms to PN-EN 10025 and PN-EN 10149
Steel grade: S235JR, S355J2 or S355MC
Yield strength for this steel is 235 MPa and 355 MPa.

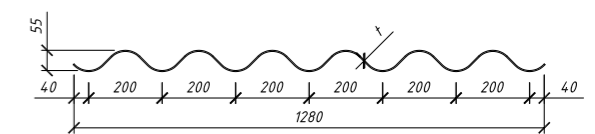

Fig.1. Cross section of a MultiPlate MP200 plate

Standard length of plate is $n \times s + 120$, where $s = 235$ mm, and $n = 4 \div 10$. Standard width of plate is 1,2 m ($m = 6$). Other plate widths are available upon request (Fig. 2.).

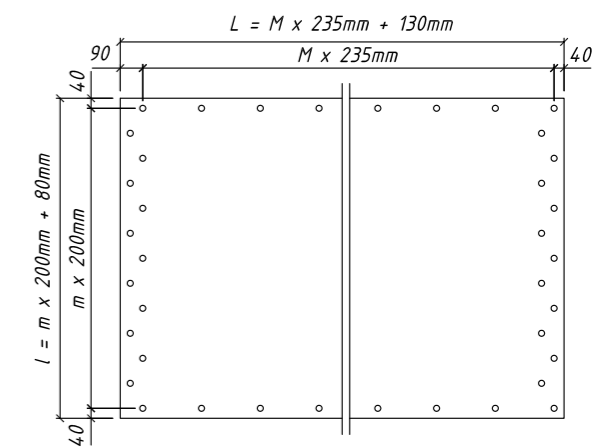
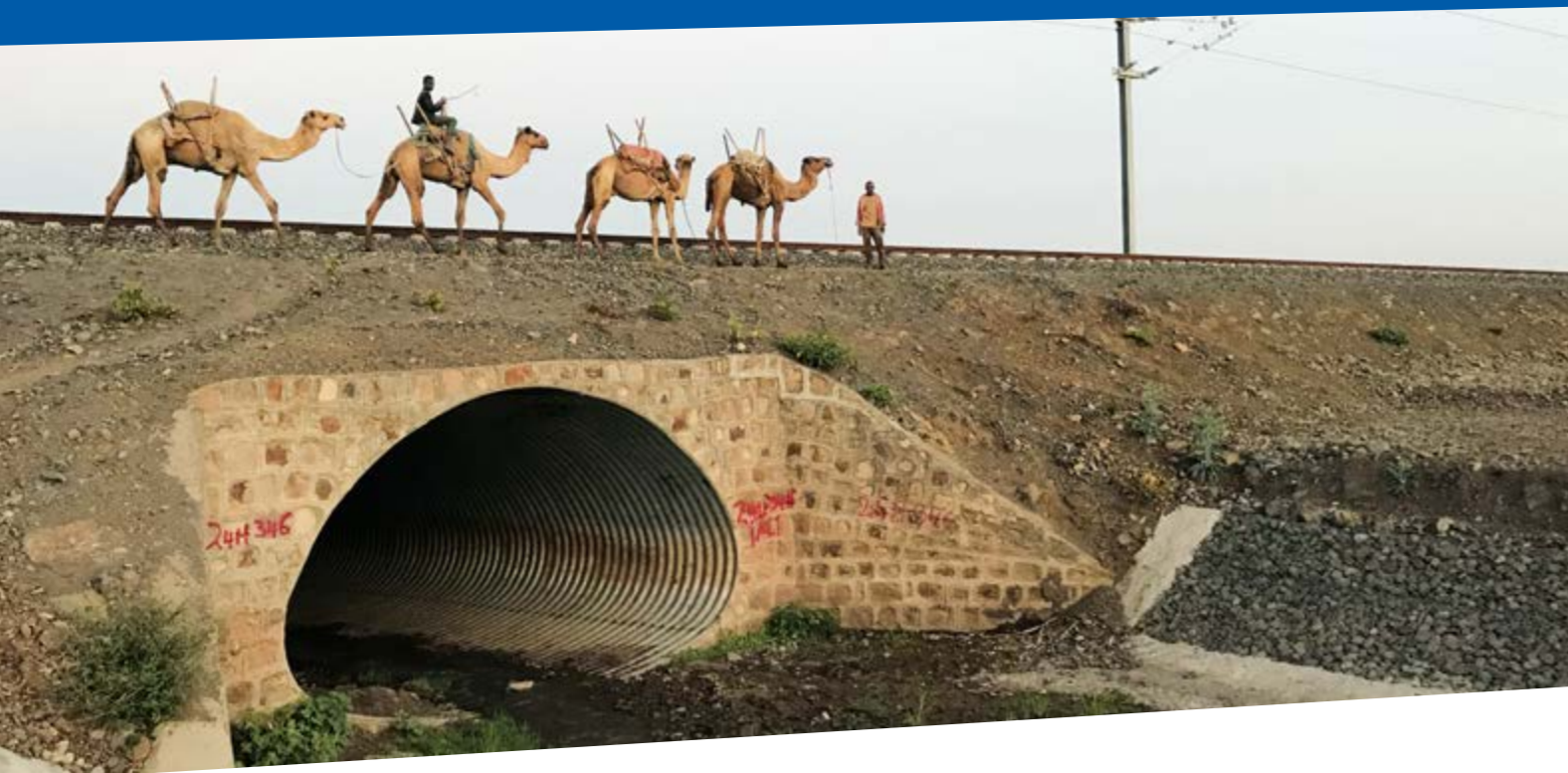

Fig. 2. Geometry of a MultiPlate MP200 plate



MultiPlate MP200



Tab. 1. Geometrical parameters of MultiPlate MP200 plate

Plate thickness [mm]	Yield strength [MPa]	Area [mm ² /mm]	Moment of inertia [mm ⁴ /mm]	Section modulus [mm ³ /mm]
3,00	235 / 355	235 / 355	1 356,36	46,77
4,00	235 / 355	4,74	1 813,80	61,49
5,00	235 / 355	5,93	2 316,15	77,20
6,00	235 / 355	7,11	2 787,57	91,40
7,00	235 / 355	8,29	3 213,20	103,65
8,00	235	9,37	3 616,77	114,82

The selection of plate thickness depends on the structure's shape, span, depth of cover and live load. Please take the opportunity to consult your design with ViaCon's Technical Department for advice and assistance with your project.

Bolts, nuts, anchor bolts

Corrugated steel plates are joined with M20 bolts class 8.8. The lengths of the bolts are related to thickness of connected plates and type of connection. There are two types of bolt heads – oval-shaped and cone-shaped with dimensions: 32 mm, 37 mm, 45 mm, 50 mm, 70 mm. The bolt diameter of 20 mm and associated nuts correspond to the requirements norm of PN-EN ISO 898-1 and PN-EN 20898-2.

Anchor bolts casted into concrete with a diameter of 20 mm and length of 225 mm or 365 mm which are cast into concrete are made of steel conforming the requirements of PN-EN ISO 898-1 & PN-EN 20898-2.

All of the ancillary items mentioned above are delivered together with corrugated plates as a complete package for the structure.

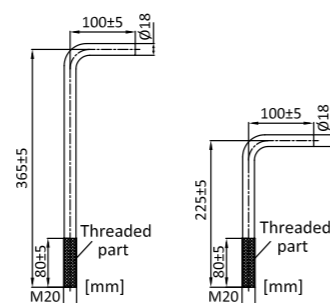

Fig. 3. Anchor bolts used to mount structure in foundation

MultiPlate MP200



Corrosion protection

Coatings applied by immersion including hot-dip galvanizing provide a durable method of corrosion protection to steel surfaces. The protection is particularly effective due to the intimate and lasting bond between the galvanizing coating and the steel surface, thereby providing extended service life. MultiPlate MP200 structures are protected by hot galvanizing as standard, with zinc coating layer according to PN-EN ISO 1461 (table 2).

Tab. 2. Zinc layer

Characteristics	Requirements acc. PN-EN ISO 1461	
	Minimal local zinc coating thickness [μm]	Minimal average zinc coating thickness [μm]
Steel plate:		
>6 mm	70	85
>3 mm to ≤6 mm	55	70
≥1,5 mm to ≤3mm	45	55
Bolts, nuts, anchor bolts	40	50

In order to extend the durability of MultiPlate MP200 structures, particularly in aggressive environments, additional corrosion protection can be provided by applying epoxy paint.

The protection of structures both by hot-dip galvanizing and epoxy paint creates the ViaCoat system conforming to PN-EN ISO 12944-5. Surfaces exposed to UV radiation have an additional coating of polyurethane paint layer in order to prevent discoloration.

Design

The design process of a MultiPlate MP200 structure consists of the following steps:

- design of MP200 structure (including assembly)
- design of engineered backfilling (including backfilling procedure)
- design of the foundations
- design of inlet, outlet and other associated fittings and elements

MultiPlate MP200 structures may be designed for all road and railway live load classes according to norm Eurocode EN 1991-2 or according to the relevant national standards for corrugated steel structures in the world.



MultiPlate MP200



MultiPlate MP200



Cover depth

Definition of the cover depth for road structures:

Vertical distance between top of the steel structure main barrel and top of the pavement including the pavement layer.

Definition of the cover depth for rail structures:

Vertical distance between the top of the steel structure barrel and bottom of the railway sleeper.

Tab. 3. Cover depth

Type of object	Minimum cover depth
Structures under roads	$H_{min} = \max \begin{cases} (S_i/8) + 0,2 \text{ [m]} \\ S_i/6 \text{ [m]} \\ 0,6 \text{ [m]} \end{cases}$
Structures under railway	$H_{min} = \max \begin{cases} S_i/4 \\ 0,6 \text{ [m]} \end{cases}$

S_i – span of the structure [m]

In cases where construction traffic is assumed over a structure, the cover depth must be agreed with the Technical Department of ViaCon.

Lower cover depths may be accepted only after appropriate static calculations are made. The maximum depth of cover is designed individually for each structure. For high cover depths the load reduction techniques are available.

Structural analysis

MultiPlate MP200 structures are designed with use of one of the following design methods:

- Swedish Design Method, developed by Prof. Sundquist and Prof. Petterson,
- CHBDC - Canadian Highways Bridge Design Code,
- AASHTO LRFD Bridge Design Specifications,
- finite element method (FEM) in complex cases.
- Or other design methods as required for the region

Geometry of structure in longitudinal direction

The base length of MultiPlate structures should conform to the following formula:

$$L_d = 40 + n \times 1200 + 40 \text{ [mm]}$$

where n = number of full rings along the length and each ring is 1200 mm long.

Top length of a structure is determined individually (considering inlets and outlets).

Ends of MultiPlate MP200 structures can be squared or beveled to match the embankment slope (Fig. 4). For structures curved in plane multiple linear increments are used to align to the designed curvature.

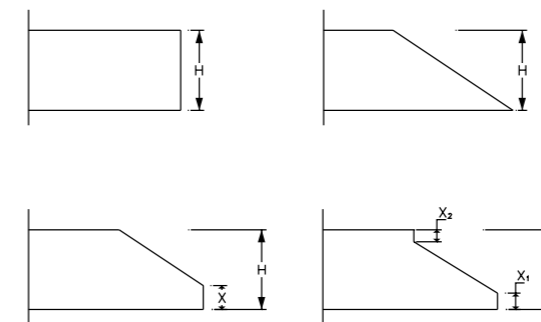

Fig. 4. End finishings for MultiPlate MP200 structures

Depending on whether the structure ends are required to be vertical or sloping the inlet and outlet, finishing details vary accordingly. If structure is vertically cut, a headwall continuously surrounding the structure's opening would be required. For beveled structures with a sloping end, the slope may be finished with grass, block-paving, gabions, reinforced earth or other end treatments.



MultiPlate MP200



Skew angles

Special consideration is required for skew angles smaller than 55 degrees. Concrete collars and/or reinforced soil can be applied to the inlet and outlet zones.

Please contact ViaCon's Technical Department for advice.

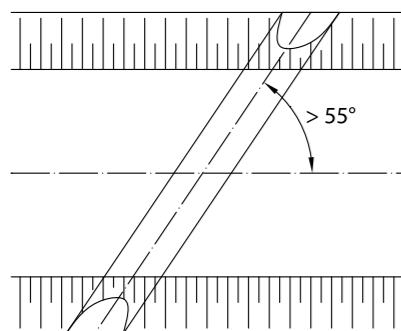

Fig. 5. Skewed structure

Concrete collar

Concrete collar is used:

- in order to stiffen inlet and outlet of the MultiPlate structure with beveled ends
- when the finishing element is used as support of the end treatment

A concrete collar is generally applied in the following cases:

- structures with skew angles to the road axis, when skew angle on outlet and inlet is $\leq 55^\circ$ and span is $> 3,5$ m
- structures exceeding 6,0 m span
- excessive skews

For smaller objects which do not meet the above criteria, stiffened collar or other types of finishing may also be used, depending on the designers decision.

Concrete collar's steel face

The stiffening collar's geometry is based on lines smoothly curved in the three-dimensional space. This makes the construction of formworks complex and time-consuming.

In order to simplify the process of casting the concrete collars, ViaCon delivers steel structures with a steel collar that acts as a stay in place form, fitted to their smooth geometry. Ordering the structure with such elements makes the casting of the concrete collar easier and accelerates the construction process.

Multiple installation

For multiple structure installations, the minimum clear spacing between adjacent structures should be sufficient for the placement and compaction of soil (Fig. 6).

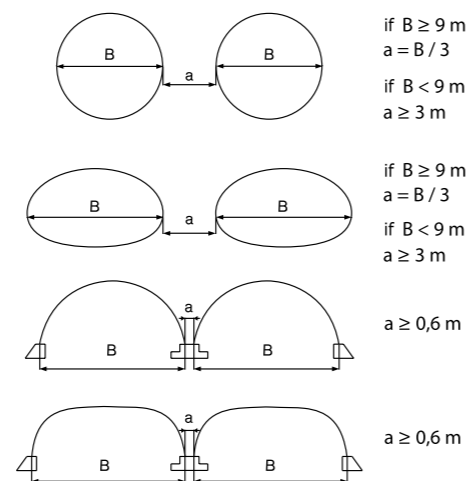

Fig. 6. Minimum clear spacing for multiple installations

MultiPlate MP200



The minimum spacing requirement depends on the shape and size of structures. When the required distance cannot be achieved, the space between structures should be filled with C12/15 concrete or cement stabilized soil to the level where the distance between structures is not less than 10% of the structure span. Please contact ViaCon's Technical Department for advice.



Fot. 1. Flat steel attached to the structure with an open cross-section



Fot. 2. Connection of MultiPlate MP200 structure with concrete footing

Foundation

Closed shape MultiPlate structures (round, elliptical, pipe-arch) are placed on soil bedding as follows:

- minimum thickness of soil bedding should be 30 cm
- the top surface portion of the bedding should be shaped to fit to the bottom plates of a structure
- particular care should be exercised in compacting soil under the haunches
- top 5 - 15 cm of the bedding should be relatively loose material so that the corrugation can delve

MultiPlate MP200 structures with open shapes are placed on concrete (Fot. 2) or flexible (Fot. 3) footings.

The structures may be attached to rock foundation with use of a flat steel plate (Fot. 1).

Other solutions should be consulted with the Technical Department of our company.



Fot. 3. Connection of MultiPlate MP200 structure with flexible footing

MultiPlate MP200



Bedding and backfill

Material:

- gravel, sand-gravel mix, well graded aggregates and crushed stone can be used as bedding and backfill material
- aggregate grain size depends on size of corrugation profile; for 200x55 mm corrugations the max recommended aggregate particle size is 45 mm
- aggregate particle size should be 0-45 mm, uniformity coefficient $C_u \geq 4,0$, curvature coefficient $1 \leq C_c \leq 3$ and permeability $k_{10} > 6$ m/24 hours
- the use of cohesive soil, organic soil and any frozen soils is not acceptable
- backfill material should be placed around the structure in uncompacted layers not more than 30 cm thick and then compacted
- the backfill should be placed on both sides of the structure at the same time or alternating from one side of the structure to the other side to keep close to the same elevation on both sides of the structure at all times. No more than one layer (30 cm) difference in elevation is permitted for one side to the other. Each layer must be compacted to the specified compaction index before adding the next layer
- backfill material adjacent (up to 20 cm) to the structure should be compacted to minimum 95% of normal Proctor density and to 98% of normal Proctor density - in the remaining area

Deviation from these principles requires consultation with the ViaCon's Technical Department.



MultiPlate MP200



Protection against water ingress

In order to protect structures against water infiltrating through the backfill, protective measures may be applied. Typically a layer of 1.0 mm thick HDPE geomembrane enclosed by two layers of protective non-woven geotextile (nominally 500g/m²) may be placed over the steel structures. For some overpasses this infiltration protection has been provided using two layers of bentonite mat (geosynthetic clay liner).

Exceptions to the above are possible after consultation with ViaCon's Technical Department. Placing the membrane directly on the structures is allowed provided that protection layers are applied.

End treatment (inlet/outlet)

Slopes may be finished by paving with locally available stones, blocks, etc. If gabion mattresses are used, additional waterproofing should be considered. Please contact ViaCon's Technical Department for advice.

For vertically cut structures, as an alternative to reinforced concrete headwalls, MSE (reinforced soil) walls may be applied using either concrete blocks, panels or gabions. If required, the ground around the MultiPlate MP200 construction can easily be reinforced during the backfilling process with geosynthetics.

Durability

Following factors have influence on structure's durability:

- aggressiveness of the environment
- abrasion
- level of corrosion protection
- plate thickness
- quality and frequency of maintenance

Procedures to verify the durability of MultiPlate structures:

- define the function of the structure
- define the required durability/design life of the structure
- define the aggressiveness of the environment (water, backfill, air)
- select the type of profile (shape of cross section)
- specify the plate thickness based on static calculations (acc. to Sundquist-Petterson method)
- specify the corrosion protection (thickness of zinc coating, paint coating, extent of the of painting, procedure)
- define annual loss of the protection layers in the upper and lower part of a structure
- calculate the structure durability by considering the corrosion progress over service lifetime
- compare calculated durability with the required

MultiPlate MP200



MultiPlate MP200

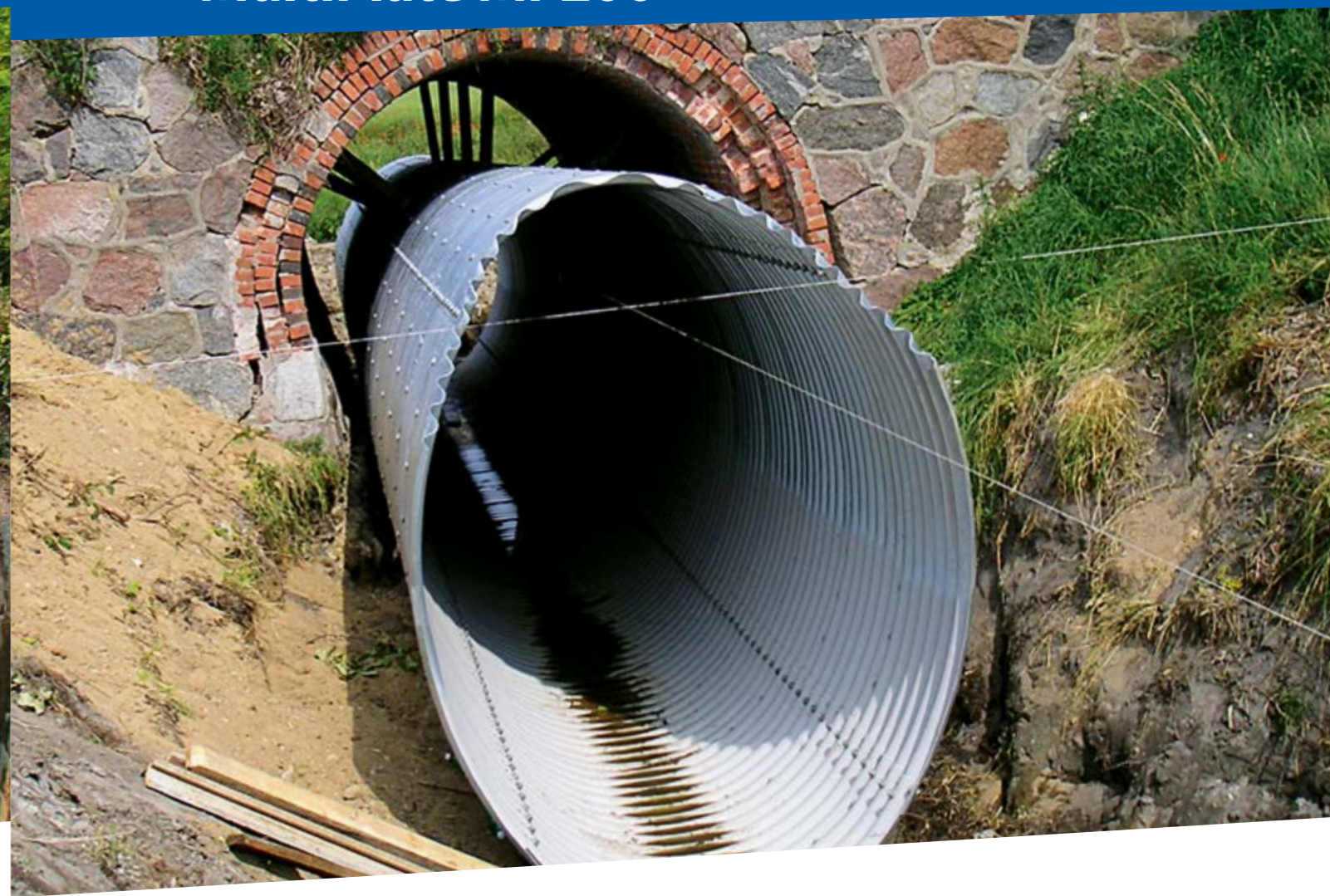

In cases, when the durability of MultiPlate MP200 structure is not sufficient, the following measures can be adopted:

- change the corrosion protection (thickness of zinc layer, paint coat)
- increase the plate thickness
- change profile (cross section shape) to reduce internal forces and increase sacrificial steel for corrosion.

Synergetic effects mean that the durability of a ViaCoat system is higher than the sum of durability of the individual protection layers and can be calculated as:

$$S_D = \alpha (S_C + S_Z)$$

where:

S_D – total durability of the protection layer

S_C – durability of zinc coat

S_Z – durability of the epoxy coat

α – synergy factor (from 1.5 to 2.0) (for 200 μ m thick paint layer $\alpha = 1.5$, for 400 μ m thick paint layer – $\alpha = 1.75$)

Relining

MultiPlate MP200 structures are also commonly used to repair old culverts and bridges where it is not possible or desirable to construct a replacement. This method is termed relining. A corrugated steel structure is placed inside an existing old structure (bridge/culvert/underpass) and the space between the old structure and a new structural plate is filled with concrete of class minimum C16/20.

This relining method allows the strengthening of the structures without traffic interruption and eliminates the need to remove/demolish the old structure. This may have the added benefit of retaining the character and aesthetics of the old structure.

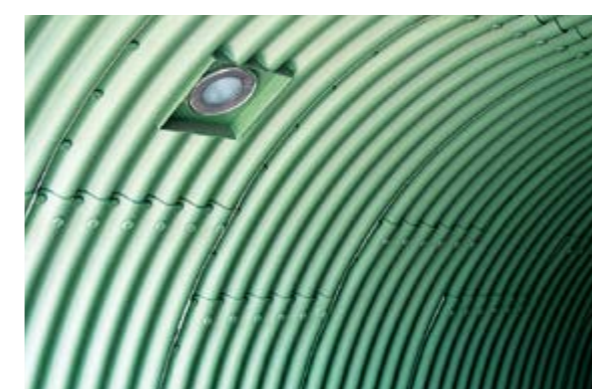

Fittings

MultiPlate MP200 structures can be equipped with additional elements depending on function of the structure e.g.:

- lighting boxes
- ventilation
- niche
- skylight
- connector pipes
- shelves for animals
- technical holes
- others



SuperCor[®]



A NEW GENERATION BRIDGES





SuperCor® versatile structures are used for roads, railways and industrial applications as well as for reinforcement and reconstruction of existing structures such us:

- bridges
- overpasses
- tunnels
- culverts
- underpasses
- pedestrian tunnels
- ecological crossings
- hangars, shelters
- underground storages
- conveyor belt protection

Introduction

SuperCor® structures are the new generation of flexible structures made of galvanized corrugated steel plates with a very high stiffness.

To bear the loads, those structures use interaction with the surrounding backfill soil. The load capacity of SuperCor® is far greater than traditional structures made of corrugated steel. SuperCor® structures are used for building engineered structures above and under roads and railways. Spans can reach 25 m.

Structures are simple and easy to assembly. Average assembly time takes a few days with assistance of small crew.

The beginning of SuperCor® dates back to the middle of the 1980's. Nowadays they have been used in many countries all over the world; in Poland ViaCon has been producing SuperCor® structures since 2008.

SuperCor® structures are designed for all road and railway live load classes according to Eurocode EN 1991-2:2003 or according to various national standards.



Approvals and Certificates:

- SuperCor® has the CE Certificate of Factory Production Control No. 1023-CPR-0640 F according to EN 1090-1+A1:2012
- Technical opinion of the Central Mining Institute (GIG):

Typical sequence for construction of SuperCor® bridges:

- construction of foundations
- delivery
- assembly
- backfilling
- finishing works

SuperCor® structures have many advantages over traditional bridge solutions:

- simple design thanks to standard details, drawings and calculations for most applications
- easy and fast assembly
- assembly possible in cold weather
- assembly possible with no traffic interruptions
- assembly possible with total or partial prefabrication of the structures
- thanks to their light weight, the corrugated steel plates can be delivered easily and economically to remote locations
- reduction in the total time and cost of construction

Production

The SuperCor® production process involves the mechanical shaping of flat steel plates into corrugated curved plates which are later hot-dip galvanized.

Production of holes and cutting is done prior to galvanization. Corrugated plates may be epoxy painted on request. Steel used for production of SuperCor® conforms to PN-EN 10149-2 or PN-EN 10025-2.

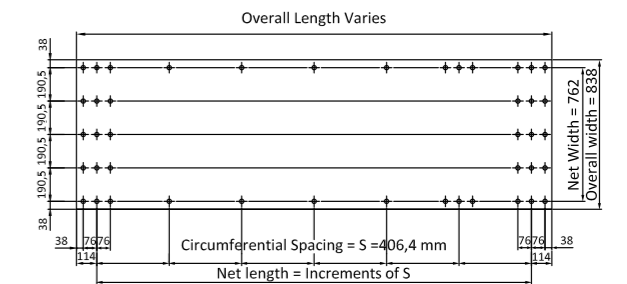

Fig. 1. Geometry of SuperCor® plate (total length, i.e. multiple S=406,4 mm)

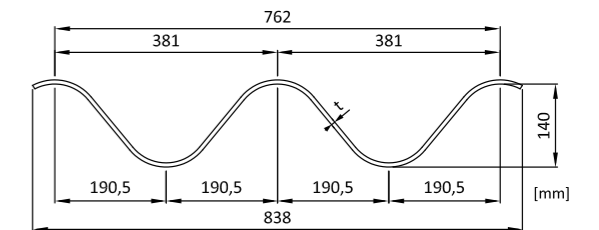

Fig. 2. Cross section of SuperCor® plate

Tab. 1. Geometrical parameters of SuperCor® plate

Plate thickness t [mm]	Yield stress [MPa]	Area [mm ² /mm]	Moment of inertia [mm ⁴ /mm]	Section modulus [mm ³ /mm]	Plastic section modulus [mm ³ /mm]
5,50	355 / 420 / 500*	7,118	16631	228,61	305,87
6,00	355 / 420 / 500*	7,767	18170	248,90	334,00
7,00	355 / 420 / 500*	9,065	21262	289,28	390,44
8,00	355 / 420 / 500*	10,365	24375	329,39	447,11

Other plate configurations are available upon request. Selection of plate thickness depends on structure shape, span, depth of cover and live load. Please take the opportunity to consult your design with the ViaCon's Technical Department for advice and assistance with your project.



Bolts, nuts, anchor bolts, base channels

Corrugated steel plates are joined with M20 bolts class 8.8. The lengths of the bolts are related to thickness of connected plates and type of connection. There are two types of bolt heads – oval-shaped and cone-shaped with dimensions: 32 mm, 37 mm, 45 mm, 50 mm, 70 mm. Bolts diameter of 20 mm and associated nuts correspond to the requirements norm of PN-EN ISO 898-1 and PN-EN 20898-2.

Anchor bolts cast into the concrete, with a diameter of 20 mm and length of 225 mm or 365 mm, are made of steel conforming to the requirements of PN-EN ISO 898-1 & PN-EN 20898-2.

All of the ancillary items mentioned above are delivered together with the corrugated plates as a complete package for the structure.

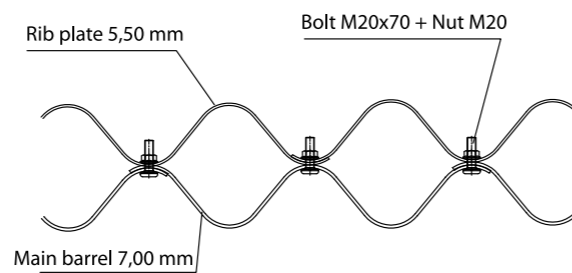

Fig. 5. Connection of ribs to main barrel plates

Corrosion protection

Coatings applied by immersion including hot-dip galvanizing provide a durable method of corrosion protection to the steel surfaces. The protection is particularly effective due to the lasting bond between the galvanizing coating and the steel surface, thereby providing extended service life. SuperCor® structures are protected by hot-dip galvanizing, with zinc coating layer according to PN-EN ISO 1461 (table 2).

In order to extend the durability of SuperCor® structures, particularly in aggressive environments, additional corrosion protection can be provided by applying epoxy paint.

The protection of structures both by hot-dip galvanizing and epoxy paint creates the ViaCoat system conforming to PN-EN ISO 12944-5. Surfaces exposed to UV radiation are additionally coated with a polyurethane paint layer in order to prevent discoloration.

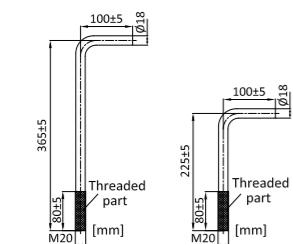

Fig. 3 Anchor bolts used to mount structure in foundation

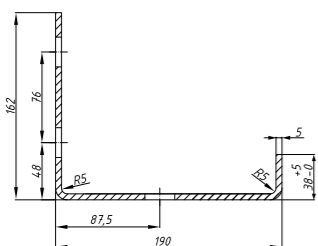

Fig. 4. Base channel used to connect structure to foundation

Tab. 2. Zinc layer

Characteristics	Requirements acc. PN-EN ISO 1461	
	Minimal local zinc coating thickness [μm]	Minimal average zinc coating thickness [μm]
Steel plate:		
> 6 mm	70	85
> 3 mm to ≤ 6 mm	55	70
≥ 1,5 mm to ≤ 3 mm	45	55
Bolts, nuts, anchor bolts	40	50
Base channel	55	70

- CHBDC - Canadian Highways Bridge Design Code,
- AASHTO LRFD Bridge Design Specifications,
- finite element method (FEM) in complex cases.

Cover depth

Definition of the cover depth for road structures:

Vertical distance between the top of a steel structure and top of the pavement including the pavement layers.

Definition of the cover depth for rail structures:

Vertical distance between the top of a steel structure and bottom of railway sleeper.

Lower cover depths may be accepted only after appropriate static calculations. The maximum depth of cover is designed individually for each structure. For high cover depths the load reduction techniques are available.

Minimum cover depth also depends on the thickness of the pavement layer (G_n) and should not be less than:

$$H = G_n + 0,15 \text{ [m]}$$

Tab. 3. Cover depth

Type of construction	Min. cover depth
Box structures	$0,45 \leq H \leq 1,5 \text{ [m]}$
Other construction	$H = 0,1 \times B \text{ [m]}$

Design

The design process of a SuperCor® structure consists of the following steps:

- design of the SuperCor® structure (including assembly)
- design of engineered backfilling (including backfilling procedure)
- design of the foundations
- design of inlet, outlet and other associated fittings and elements

SuperCor® structures may be designed for all road and railway live load classes according to norm Eurocode EN 1991-2 or according to the relevant national standards for corrugated steel structures in the world.

Structural analysis

SuperCor® are designed with use of one of the following methods:

- Swedish Design Method, developed by Prof. Sundquist and Prof. Petterson,



Geometry of structure in longitudinal direction

The base length of SuperCor® structures should conform to the following formula:

$$L_d = 38 + n \times 762 + 38 \text{ [mm]}$$

where n – number of full rings along the structure

Top length of a structure is determined individually (considering inlets and outlets).

The ends of SuperCor® structures can be squared or beveled to match the embankment slope (Fig.6). For structures curved in plane multiple linear increments are used to align to the designed curvature.

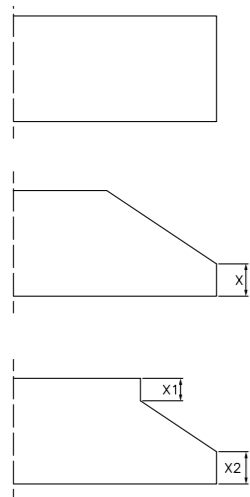

Fig. 6. End finishes of SuperCor®

Skew angles

Special consideration is required for skew angles less than 55 degrees. Concrete collar and/or reinforced soil can be applied to the inlet and outlet zones.

Please contact ViaCon's Technical Department for advice.

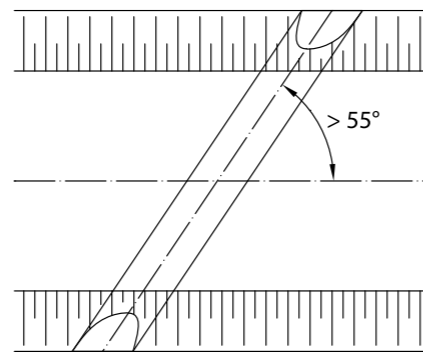

Fig. 7. Skewed structure



Reinforcing ribs

Reinforcing ribs should be used when flexural capacity of the section is exceeded. Ribs can be used for all shapes of structures if required.

Reinforcing ribs placement (Fig. 8):

- only in crown
- in crown and haunch
- around whole perimeter

Longitudinal section (Fig. 9)

- continuous (ribs spacing - 762 mm) – placed on the whole top length of the structure
- spaced at intervals of 1143 mm or 1524 mm

In order to increase the capacity, the void between main barrel and reinforcing ribs can be filled with concrete (EC ribs).

The use of EC ribs can be necessary for large span structures. C25/30 concrete is used as filling.

Filling of the voids results with increase of the sectional parameters of the steel shell.

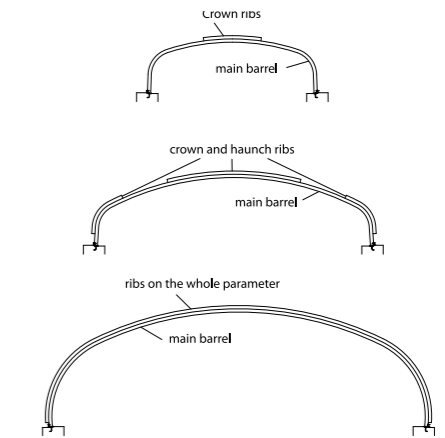

Fig. 8. Placement of the ribs in cross section of the structure

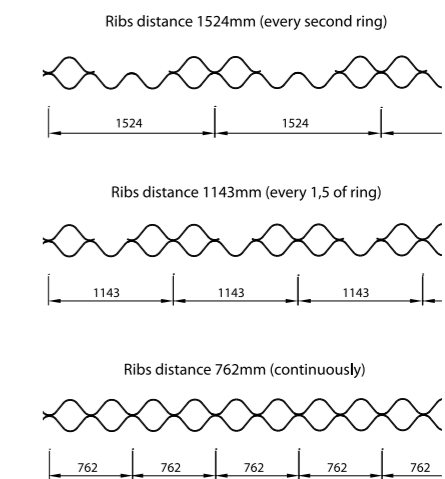

Fig. 9. Placement of the ribs in longitudinal direction of the structure





Multiple installation

For multiple structure installation, the minimum clear spacing between adjacent structures should be sufficient for the placement and compaction of soil (page 32 fig. 6)

The minimum spacing requirement depends on the shape and size of structures. When the required distance cannot be achieved, the space between structures should be filled with C12/15 concrete or cement stabilized soil to the level where the distance between structures is not less than 10% of the structure span. Please contact ViaCon's Technical Department for advice.



Foundation

Closed shape SuperCor® structures (round, elliptical, pipe-arch) are placed on soil bedding as follows:

- minimum thickness of soil bedding should be 60 cm
- the top surface portion of the bedding should be shaped to fit to the bottom plates of a structure
- particular care should be exercised in compacting soil under the haunches
- top 5 - 15 cm of the bedding should be relatively loose material

SuperCor® structures with open shapes are placed on concrete or flexible footings.

Other solutions should be discussed with the ViaCon Technical Department.

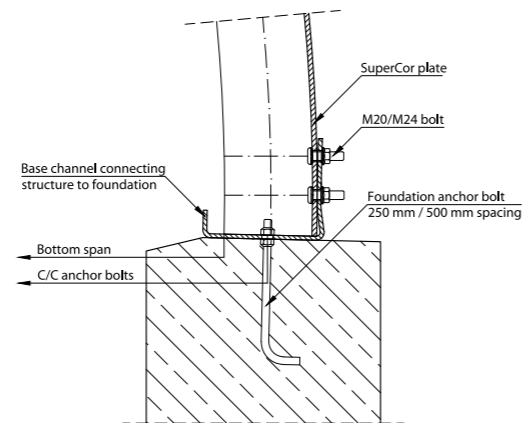

Fig. 10. Connection of SuperCor® structure with concrete footing

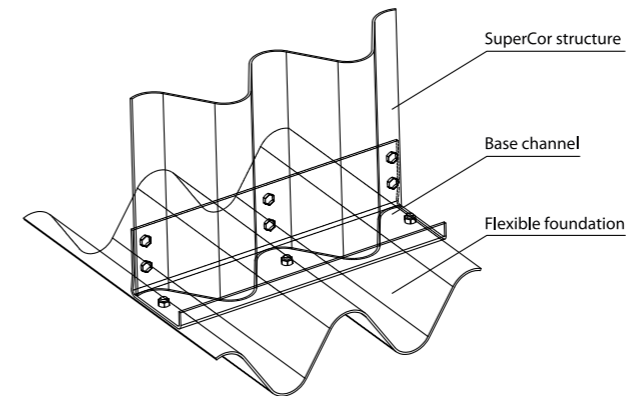
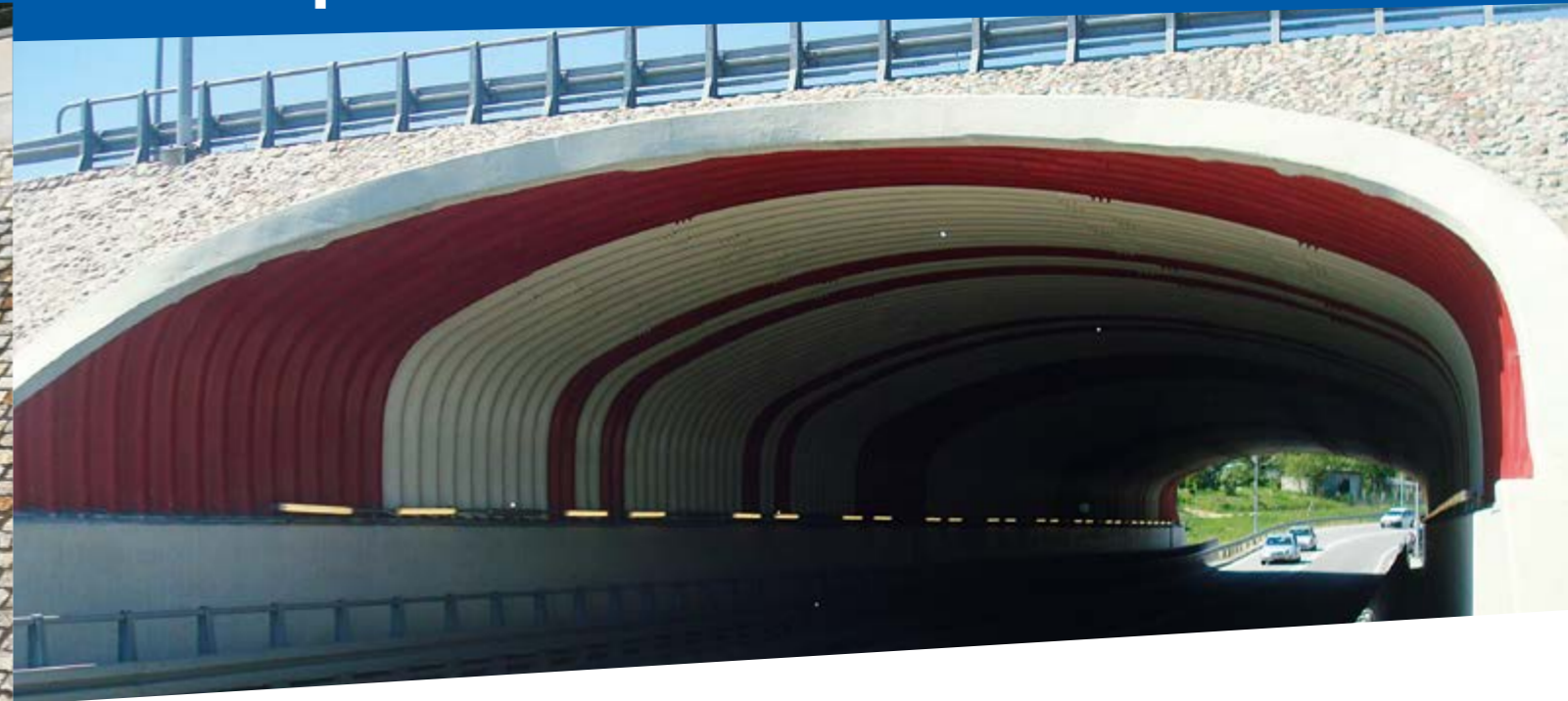

Fig. 11. Connection of SuperCor® structure with flexible footing

The structures are connected to the concrete footings with use of anchor bolts, taking the following rules into account:

- anchor bolts for concrete foundations should be installed in concrete footings prior to delivery of a SuperCor® structure
- anchor bolts should not stick out from the top of the footing more than 40 mm
- placing of anchor bolts should conform to the assembly drawing; the allowable tolerance is ± 3 mm in the longitudinal direction and ± 2 mm in the transverse direction
- to minimize the risk of mistake, the location of each anchor should be measured from the starting point (first anchor)
- parallel placement of anchor bolts on each footing and perpendicular placement of each pair of anchor bolts for individual rings are of great importance; the better the accuracy, the easier it is to assembly of the structure





Bedding and backfill

- gravel, sand-gravel mix, well graded aggregates and crushed stone can be used as bedding and backfill material
 - aggregate grain size depends on size of corrugation profile; for 381 x 140 mm corrugations the max recommended aggregate particle size is 120 mm
 - aggregate particle size should be 0-120 mm, uniformity coefficient $C_u \geq 4,0$, curvature coefficient $1 \leq C_c \leq 3$ and permeability $k_{10} > 6$ m/24 hours
 - the use of cohesive soil, organic soil and any frozen soils is not acceptable
 - backfill material should be placed along the structure in uncompacted layers maximum 30 cm thick and then compacted
 - the backfill should be placed on both sides of the structure at the same time or alternating from one side of the structure to the other.
- No more than 30 cm difference in elevation is permitted from one side to the other. Each layer must be compacted to the specified compaction index before adding the next layer
- backfill material adjacent (up to 20 cm) to the structure should be compacted to minimum 95% of normal Proctor density and to 98% of normal Proctor density - in the remaining area

Deviation from these principles requires consultation with the ViaCon Technical Department.

Protection against water ingress

In order to protect structures against water infiltrating through the backfill, protective measures may be applied. Typically a layer of 1.0 mm thick HDPE geomembrane enclosed in two layers of protective non-woven geotextile (nominally 500g/m²) is placed over steel structures. For some overpasses this infiltration protection has been provided using two layers of bentonite mat (geosynthetic clay liner). Exceptions to the above are possible after consultation with ViaCon Technical Department. Placing the membrane directly on the structures is allowed provided that protection layers are applied.

End treatment (inlet/outlet)

End treatment depends on the type of the end cut.

For beveled ends, slopes can be finished by paving with stones blocks, etc.

For beveled ends with gabion mattresses, waterproof solutions must be applied.

As an alternative to concrete headwalls, MSE like ViaWall or ViaBlock® system or gabions may be applied.

Concrete collar

Concrete collar is used:

- in order to stiffen inlet and outlet of the SuperCor® structure with beveled ends
- as elements used as support for the end treatment

Concrete collar is applied mostly in following cases:

- structures are designed in skew to road axis, when skew angle on outlet and inlet is $\leq 55^\circ$ and span is $> 3,5$ m
- structures exceed 6,0 m span
- large skews

In other cases concrete collar can be used as support for slope pavement

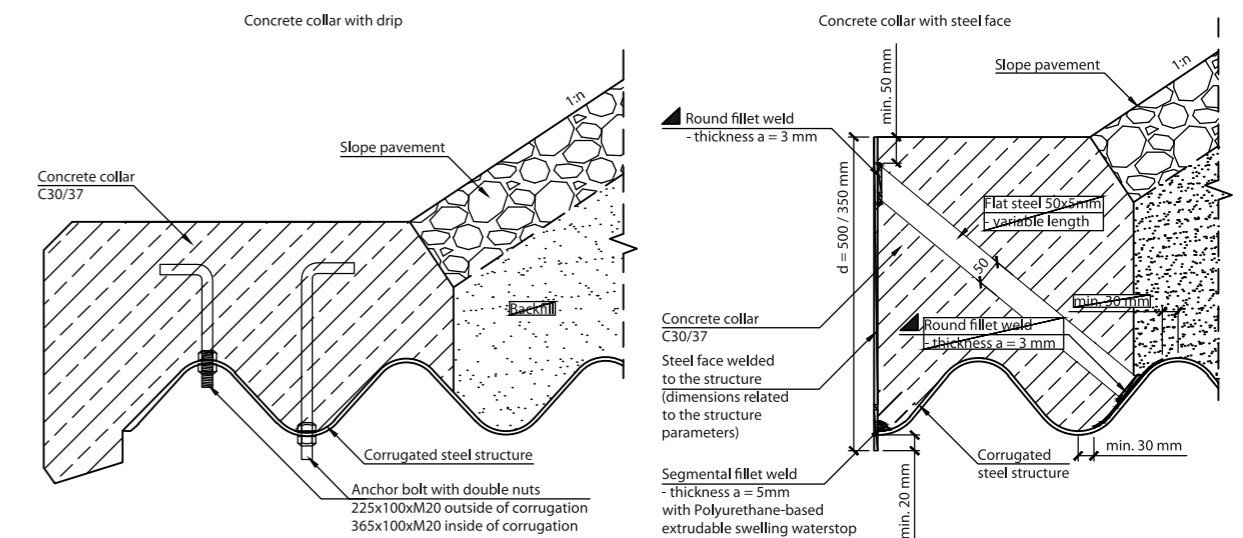

Fig. 12. Example of a concrete collar on inlet and outlet of the structure

Concrete collar's steel face

The stiffening collar's geometry is based on lines smoothly curved in the three-dimensional space. This makes the construction of formworks complex and time-consuming. In order to simplify the process of casting the concrete collars,

ViaCon delivers steel structures with steel face collars, fitted to their smooth geometry. Ordering the structure with such elements makes the casting of the concrete collar easier and accelerates the construction process.



Durability

The following factors have influence on a structure's durability:

- aggressiveness of the environment
- abrasion
- level of corrosion protection
- plate thickness
- quality and frequency of maintenance

Extended corrosion protection may be applied:

- inside and/or outside on the whole area of a structure
- at inlet and outlet of the structure (1,5 m inside the structure)
- inside up to 0,5 m above mean water level
- as a combination of above mentioned

Most common thickness of epoxy paint is 200 µm, however other thicknesses are possible.



Procedure to verify the durability of SuperCor® structures:

- define the function of the structure
- define the required durability/design life of the structure
- define the aggressiveness of the environment (water, backfill, air)
- select the type of profile (shape of cross section)
- specify the plate thickness based on static calculations (acc. to Sundquist-Petterson method)
- specify the corrosion protection (thickness of zinc coating, paint coating, extent of painting, procedure)
- define annual loss of the protection layers in upper and lower part of a structure
- calculate the structure durability by considering corrosion loss over service lifetime
- compare calculated durability with the required



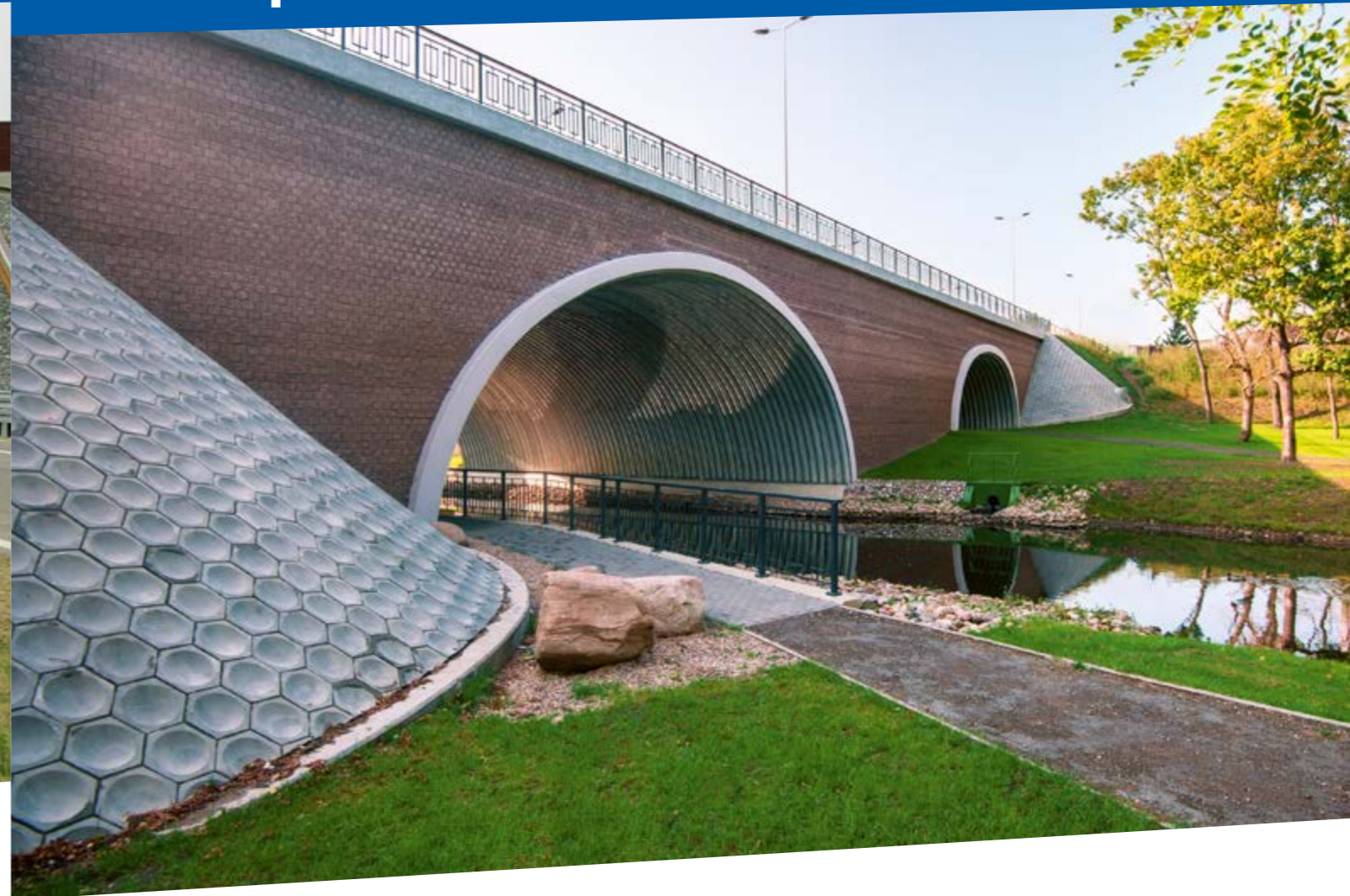

In cases, when the durability of a SuperCor® structure is not sufficient, the following measures can be adopted:

- change the corrosion protection (thickness of zinc layer, paint coat)
- increase the plate thickness
- change profile (cross section shape) to reduce internal forces and increase sacrificial steel for corrosion.

Synergistic effects mean that the durability of a ViaCoat system is higher than sum of durability of the individual protection layers and can be calculated as:

$$S_D = \alpha (S_C + S_Z)$$

where:

S_D – total durability of the protection layer

S_C – durability of zinc coat

S_Z – durability of the epoxy coat

α – synergy factor (from 1.5 to 2.0) (for 200 μ m thick paint layer $\alpha = 1.5$, for 400 μ m thick paint layer – $\alpha = 1.75$)



Relining

SuperCor® structures are commonly used to repair old culverts and bridges where it is not possible or desirable to construct a replacement. This method is termed relining. A corrugated steel structure is placed inside an old and existing structure (bridge/culvert/underpass) and the space between the old structure and a new structural plate is filled with concrete of class minimum C16/20.

This relining method allows the strengthening of the structures without traffic interruption and eliminates the

need to remove/demolish the old structure. This may have the added benefit of retaining the character and aesthetics of the old structure.

In the case of relining with open-shaped structures, a concrete footing connected to existing foundation is usually required. Existing footings can also be used but would require a separate analysis to ensure it meets the design requirements.

Researches made in the years 2000-2007 confirmed increased of capacity of relined structures.





Fittings

SuperCor® structures can be equipped with additional elements depending on function of the structure e.g.:

- lighting boxes
- ventilations
- niches
- shelves for animals
- technical holes
- skylights
- connector pipes
- others



UltraCor[®]



THE NEWEST GENERATION OF FLEXIBLE STRUCTURES





UltraCor® versatile structures are used for roads, railways and industrial applications as well as for reinforcement and reconstruction of existing structures such as:

- bridges
- overpasses
- tunnels
- culverts
- underpasses
- pedestrian tunnels
- ecological crossings,
- hangars
- shelters
- underground storages

Introduction

UltraCor® structures are the new generation of flexible structures made of galvanized corrugated steel plates. As the world's deepest corrugation profile, UltraCor® combines all the advantages of lightweight construction with previously unheard-of strength and durability to create the largest corrugated steel structures in the world today.

UltraCor® structures are designed for all road and railway live load classes as well as under the load of special vehicles.

Approvals and Certificates:

CE Certificate according to norm EN 1090-1.

Corrugation:

The UltraCor® corrugation profile is 500 x 237 mm.

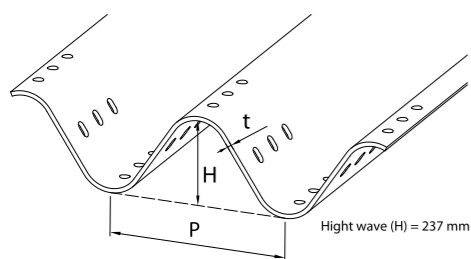

Fig. 1. Wave profile of UC plate

UltraCor® structures have many advantages over traditional bridge solutions:

- larger structure end area
- larger bearing of the structure
- higher range of cover depth
- lower costs of transportation
- reduction in total time and cost of building a bridge
- fast and easy assembly

Product features:

- the highest structural strength among the buried flexible steel structure in the world
- large range of shapes and sizes
- easy and short installation time
- **spans of 30 m and greater**

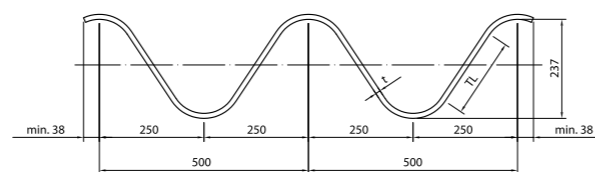

Fig. 2. Cross section of UltraCor® plate

Production

The UltraCor® process involves the mechanical shaping of flat steel plates into corrugated curved plates which are later hot-dip galvanized.

The finished corrugated plates can also be epoxy painted on request.

All of the manufacturing is completed in a quality controlled factory process. Steel used for production of UltraCor® conforms to EN 10149-2 or EN 10025-2, Steel grade S355MC, S420MC and S500MC.



Bolts, nuts, anchor bolts, base channels

Corrugated steel plates are joined by bolts M22 or M24 (class 8.8, 10.9). The lengths of bolts are related to thickness of connected plates and type of connection (45, 60, 80 mm).

Bolts and nuts are made of steel according to EN ISO898-1 and EN ISO 898-2.

Anchor bolts casted into concrete with a diameter of 22 mm and length of 225 mm or 430 mm are made of steel conforming to the requirements of EN 10025-2:2007.

Base channels have dimensions of 260 x 310 x 70 x 10 and conform to norm EN 10025-2.

All of the ancillary items mentioned above are delivered together with corrugated plates as a complete package for the structure.

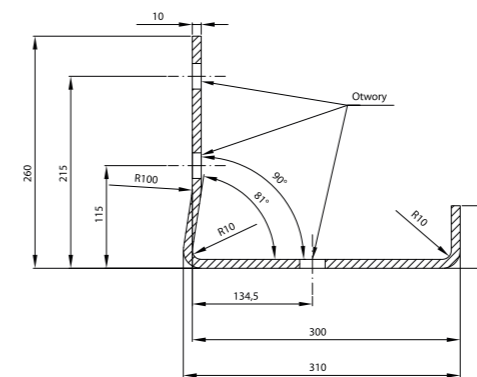

Fig. 3. Base channel used to connect structure to foundation

Corrosion protection

Coatings applied by immersion including hot-dip galvanizing provide a durable method of corrosion protection to steel surfaces. The protection is particularly effective due to the lasting bond between the galvanizing coating and the steel surface, thereby providing extended service life. The zinc coating layer on UltraCor® structures are according to PN-EN ISO 1461 (table 1).

Tab. 1. Zinc layer

Characteristics	Requirements acc. PN-EN ISO 1461	
	Minimal local zinc coating thickness [µm]	Minimal average zinc coating thickness [µm]
Steel plate:		
>6 mm	70	85
>3 mm to ≤6 mm	55	70
Bolts, nuts, anchor bolts	40	50
Base channel	70	85

In order to extend the durability of UltraCor® structures, particularly in aggressive environments, additional corrosion protection can be provided by applying epoxy paint.

The protection of structures both by hot-dip galvanizing and epoxy paint creates the ViaCoat system conforming to PN-EN ISO 12944-5. Surfaces exposed to UV radiation are also coated with a polyurethane paint layer in order to prevent discoloration.



Design

The design process of an UltraCor® structure consists of the following steps:

- design of the UltraCor® structure (including assembly)
- design of engineered (backfilling procedure)
- design of the foundations
- design of inlet, outlet and other associated fittings and elements

UltraCor® structures may be designed for all road and railway live load classes according to norm Eurocode EN 1991-2 or according to the relevant national standards for corrugated steel structures in the world.

Structural analysis

UltraCor® are designed with use of one of the following methods:

- Swedish Design Method, developed by Prof. Sundquist and Prof. Petterson,
- CHBDC - Canadian Highways Bridge Design Code,
- AASHTO LRFD Bridge Design Specifications,
- finite element method (FEM) in complex cases.

Cover depth

Definition of the cover depth for road structures

Vertical distance between top of a steel structure main barrel and top of the pavement including the pavement layer.

Tab.3. Cover depth

Type of construction	Min cover depth
Arched construction – low profiled	$H = 1/12 \times B$ [m]

Minimum cover depth also depends on the thickness of the pavement layer (Gn) and should not be less than:

$$H = Gn + 0,15 \text{ [m]}$$

Definition of the cover depth for rail structures

Vertical distance between top of a steel structure main barrel and bottom of railway sleeper.

Lower cover depth is permissible when appropriate static calculations are conducted.

In cases where construction traffic is travelling over a structure, the cover depth must be checked by ViaCon's Technical Department.

Geometry of a structure in longitudinal direction

The base length of UltraCor® structures should conform to the following formula:

$$Ld = 38 + n \times 1000 + 38 \text{ [mm]}$$

where n – number of full rings alongside length

Top length of a structure varies depending on each jobsites constraints. (considering inlets and outlets).

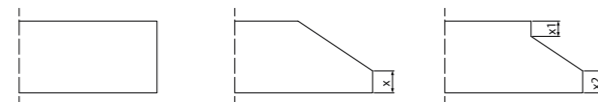

Fig. 4. End finishes of UltraCor®



Skew angles

Special consideration is required for skew angles smaller than 55 degrees. Concrete collars and/or reinforced soil can be applied to the inlet and outlet zones.

Please contact ViaCon's Technical Department for advice.

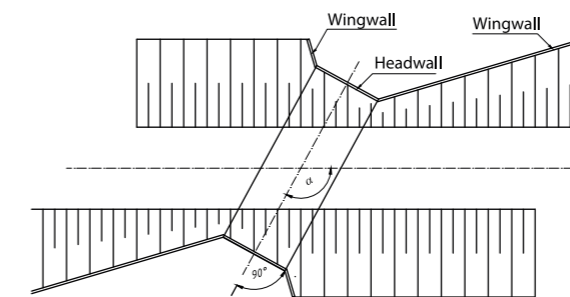

Fig. 5. Skewed structure

Multiple installation

For multiple structure installations, the smallest clear spacing between adjacent structures should be sufficient for the placement and compaction of soil. The minimum spacing requirement depends on the shape and size of structures.

All details are described in the Technical data Sheet provided by ViaCon's Technical Department.





Foundation

Closed shaped UltraCor® structures (round, elliptical, pipe-arch) are placed on soil bedding as follows:

- minimum thickness of soil bedding should be 60 cm
- the top surface portion of the bedding should be shaped to fit to the bottom plates of a structure
- particular care should be exercised in compacting soil under the hauches
- top 25 cm layer of the bedding should be relatively loose material

UltraCor® structures with open shapes (arches, boxes) are placed on concrete footings.

Connection of the structure to the concrete footings is completed by using anchor bolts, taking the following into account:

- anchor bolts for concrete foundations are to be installed in the concrete footings prior to delivery of a UltraCor® structure
- anchor bolts should not stick out from the top of the footing more than 50 mm
- placing of anchor bolts should conform to the assembly drawing; the allowable tolerance is ± 3 mm in longitudinal direction and ± 2 mm in the transverse direction
- to minimize a risk of mistake, the location of each anchor should always be measured from the starting point (first anchor)
- parallel placement of anchor bolts on each footing and perpendicular placement of each pair of anchor bolts for individual rings are of great importance; the better the accuracy, the easier the assembly of the structure

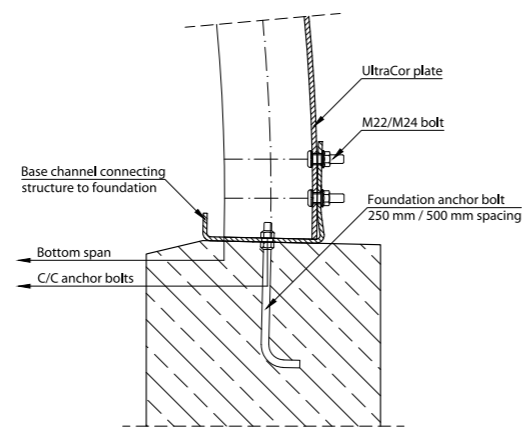

Fig. 6. Connection of UltraCor® structure with concrete footing

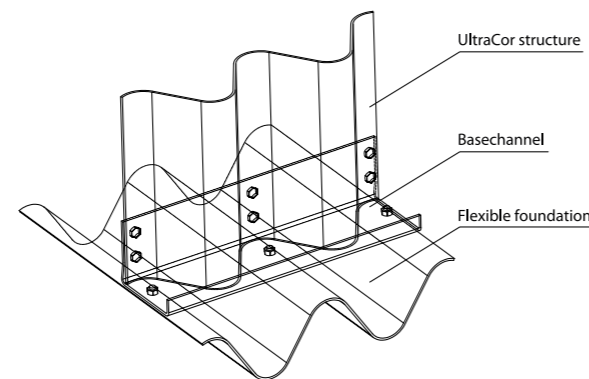

Fig. 7. Connection of UltraCor® structure with flexible footing



Bedding and backfill

- gravel, sand-gravel mix, well graded aggregates and crushed stone can be used as bedding and backfill material
- aggregate grain size depends on size of the corrugation profile; for 500x237 mm corrugations the max recommended aggregate particle size is 120 mm
- aggregate particle size should be 0-120 mm, uniformity coefficient $C_u \geq 4,0$, curvature coefficient $1 \leq C_c \leq 3$ and permeability $k_{10} > 6/24$ hours
- the use of cohesive soil, organic soil and any frozen soils is not acceptable
- backfill material should be placed around the structure in uncompacted layers maximum 30 cm thick and then compacted
- the backfill should be placed on both sides of the structure at the same time or alternating from one side of the structure to the other side. No more than one layer (30 cm) difference in elevation is permitted from one side to the other. Each layer must be compacted to the specified compaction index before adding the next layer

- backfill material adjacent to the structure should be compacted to minimum 95% of normal Proctor density and to 98% of normal Proctor density - in the remaining area unless otherwise noted

Deviation from these principles requires consultation with the ViaCon Technical Department.

Protection against water ingress

In order to protect structures against water infiltrating through the backfill protective measures may be applied. Typically a layer of 1.0 mm thick HDPE geomembrane enclosed by two layers of protective non-woven geotextile (nominally 500g/m²) may be placed over steel structures. For some overpasses this infiltration protection has been provided using two layers of bentonite mat (geosynthetic clay liner).

Exceptions to the above are possible after consultation with ViaCon's Technical Department. Placing the membrane directly on the structures is allowed provided that protection layers are applied.

Please use the ViaCon Catalogue of Production Standard Solutions and Details for more details.

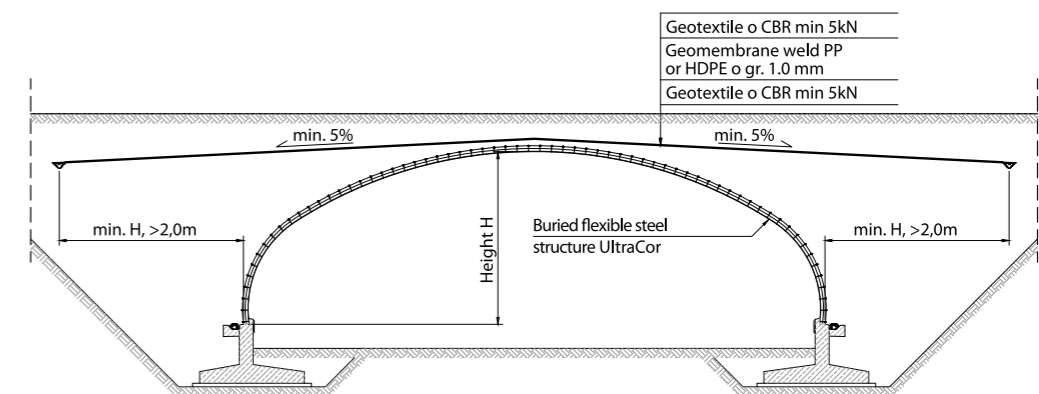

Fig 10. Scheme of rainwater protection



End treatment (inlet/outlet)

Slopes may be finished by paving with locally available stones, blocks, etc. If gabion mattresses are used, additional waterproofing should be considered. Please contact ViaCon's Technical Department for advice.

For vertically cut structures, as an alternative to reinforced concrete headwalls, MSE (reinforced soil) walls may be applied using either concrete blocks, panels or gabions. If required, the ground around the UltraCor® construction can easily be reinforced during the backfilling process with geosynthetics.

Concrete collar

Concrete collars are used:

- in order to stiffen inlet and outlet of UltraCor® structure with beveled ends
- as final element used to support the end treatment

Tolerances:

When the UltraCor® is assembled, it is recommended to take measurements of the shape of the structure.

Permissible tolerances of the structure dimensions are:

- for box structure
 - +2% of the span
 - +2%/-4% of the height
- for other shapes
 - +2% of the span
 - ±2% of the height

Deformation of the cross section after backfill should be within a tolerance of 2% of the span measured after assembly.

Fittings

UltraCor® structures can be equipped with additional elements depending on the function of the structure e.g.:

- lighting boxes
- ventilation
- niche
- shelves for animals
- technical holes
- skylight
- connector pipes
- others



Acrow

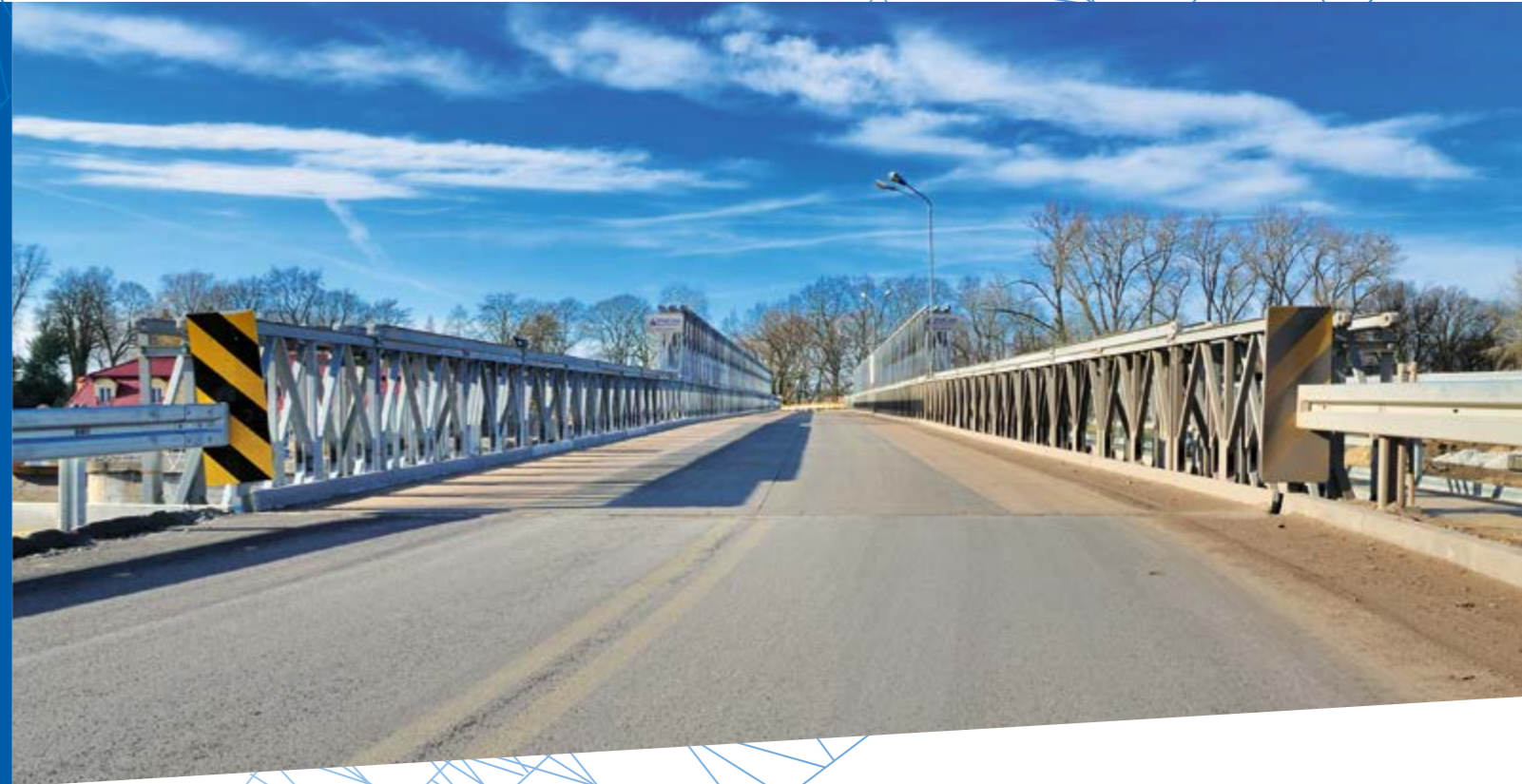

ENGINEERING IDEAS WORLDWIDE SOLUTIONS





Acrow® 700XS® bridges can be successfully used as:

- temporary bridges for service roads in construction sites
- detours during repairs of permanent bridges on public roads (in this application they allow to minimize traffic disruptions - elimination of alternating traffic, they increase the safety of the workers and allow to accelerate the works)
- permanent bridges
- permanent or temporary footbridges
- service bridges - for pipelines, etc.

Application

The Acrow® 700XS® truss bridge system is based on the Bailey bridge system, which is well known around the globe.

Acrow® 700XS® bridges have been used for many years on construction sites all over the world. Simplicity in the design and ease of assembly make them very popular. In Poland, the Acrow® 700XS® truss bridge system has obtained the Technical Approval of the Road and Bridge Research Institute No. AT/2009-03-2487.



Main elements of the system

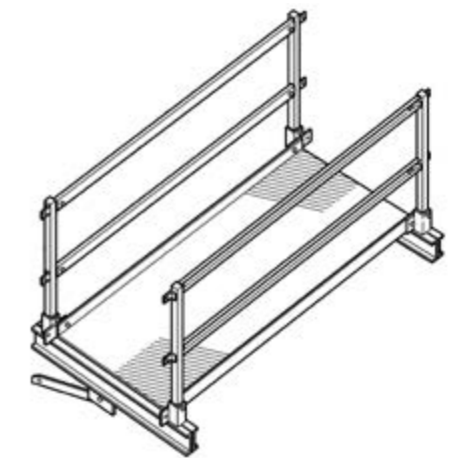
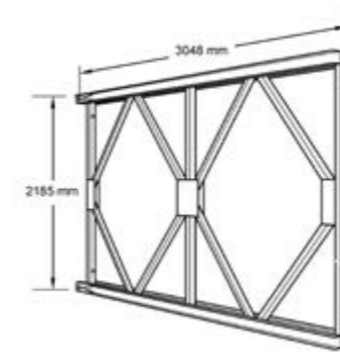

- Truss panels with the dimensions of 218.50 cm x 304.80 cm joined together with the use of bolts

- Cantilevered walkways with the width of 1.5 m, located outside the truss panels ensure separation of pedestrian traffic from the vehicular traffic, which increases the safety of pedestrians.

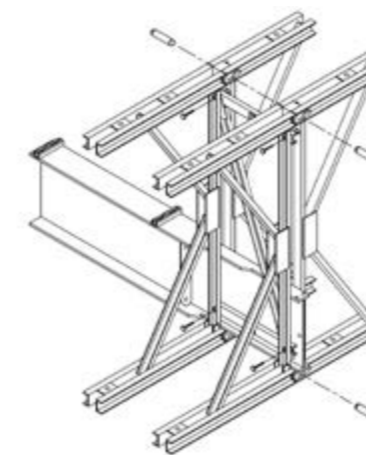

- Bracing and fasteners



Acrow



- I-profile crossbars allow building a bridge with six standard widths: 3.65m, 4.14 m, 5.48 m, 7.31 m, 9.14 m, and 10.96 m (width of the deck)
- between curbs). The crossbars are placed every 3.048 m.

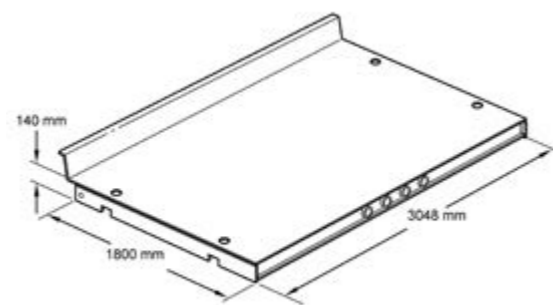

- Steel decks placed on the crossbars ensure the possibility of vehicular traffic. Surface of the bridge deck in the form of steel plate or steel plate with epoxy coating applied in the factory. It is also possible to make a wooden deck. Fixing the decks to crossbars is very simple and takes place from the level of the deck with the use of bolts



Acrow

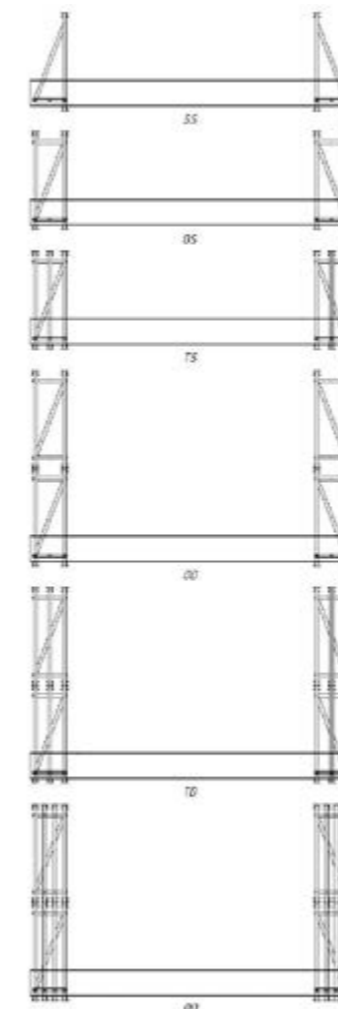

Panels can be installed in various ways to create a structure that will be adapted to any specific design requirements - it is enough to modify the configuration of the panels to change the span or enable carrying higher/lower loads. In order to provide a greater efficiency, these trusses can use light or heavy reinforcing bands.

The bridges can be built as single-span or multi-span structures. The latter can be designed as continuous structures on intermediate piers or in the form of simply supported structures, consisting of a number of individual spans.

Structural elements of the bridges are made of high-strength steel and are protected against corrosion by hot dip galvanizing (coating thickness: 610 g/m²).

A short time needed to make a crossing is the reason why Acrow® 700XS® bridges are perfect for use in the event of sudden failures of existing facilities, during implementation of road and bridge investment projects, or in areas affected by natural disasters.



Acrow



Advantages

- quick assembly and disassembly and easy adaptation to local conditions
- possibility of multiple uses in various static and assembly systems
- possibility of assembly and disassembly without any support scaffolding
- small number of different parts with uncomplicated connectors
- interchangeability of identical elements
- easy transport



Acrow



Installation methods

The most popular methods include:

- Cantilevered sliding method - it consists in assembling bridge elements on one side of an obstacle and then systematically pulling out the bridge towards an intermediate support or an abutment. Pulling out takes place with the use of installation rollers supplied with the structure.
- Structure lifting method - it consists in assembling a bridge and lifting its entire structure onto the prepared abutments. In such a case, it is recommended to leave the structure without placing the deck and making the deck after placing the span on the target supports.





ViaCon Sp. z o.o.
Przemysłowa 6
64-130 Rydzyna, Poland
tel.: (+48) (65) 525 45 45
fax: (+48) (65) 525 45 55
e-mail: office@viacon.pl
www.viacon.pl

